

Customer :

No. F3853612M

Date : Nov. 16, 1994

Attention :

Your ref. No :

Your Part. No : STEC11B04

SPECIFICATIONS

ALPS :

MODEL EC11B15204

Spec. No. :

Sample No. : F3853612M

RECEIPT STATUS

RECEIVED

By. Date

Signature

Name

Title

ALPS ELECTRIC CO., LTD.

HEAD OFFICE
1-7, YUKIGAYA-OHTSUKA-CHO.
OHTA-KU, TOKYO 145 JAPAN

DSG'D *H. Miura*

APP'D *S. Mizobuchi*

ENG. DEPT. DIVISION

Sales

SPECIFICATIONS

1. THIS SPECIFICATIONS APPLY TO EC11B15204 ROTARY ENCODER

2. CONTENTS OF THIS SPECIFICATIONS.

4LA211-11
LA2110423

3. MARKING

·MARKING ON ALL UNITS
DATE CODE

4. REMARKS

·FURNISH PACKAGE
NUT: 1, WASHER: 1
·NOTES

·Marking ⇒ in specifications shows standard and condition for application.

1. 一般事項 General

1-1 適用範囲 SCOPE

この仕様書は主として電子機器に用いる微小電流回路用11形薄形ロータリーエンコーダに適用する。
 This specification applies to 11mm size low-profile rotary encoder (incremental type) for microscopic current circuits, used in electronic equipment.

1-2 標準状態 Standard atmospheric conditions

測定は特に指定のない限り、次の状態で行なう。
 Unless otherwise specified, the standard range of atmospheric conditions for making measurements and tests is as follows:

温度 Ambient temperature	: 5°C to 35°C [△] 15°C to 35°C
相対湿度 Relative humidity	: 45% to 85% 25% to 85%
気圧 Air pressure	: 860hPa to 1060hPa

但し、疑義を生じた場合は、次の標準状態で行なう。

If there is any doubt about the results, measurements shall be made within the following limits:

温度 Ambient temperature	: 20 ± 2°C [△] 20 ± 1°C
相対湿度 Relative humidity	: 60% to 70% 63% to 67%
気圧 Air pressure	: 860hPa to 1060hPa

1-3 使用温度範囲

Operating temperature range : -30°C to +70°C

1-4 保存温度範囲

Storage temperature range : -40°C to +85°C

2. 構造 Construction

2-1 寸法 Dimensions

添付組立図による。
 Refer to attached drawing.

3. 定格 Rating

3-1 定格容量

Rating

D. C. 5V 10mA (1mA MIN)

4. 電気的性能 Electrical characteristics

項目 Item	条件 Conditions	規格 Specifications													
4-1 出力信号 Output signal format	<Fig 1> <table border="1" style="width:100%; border-collapse: collapse;"> <tr> <th style="width:30%;">軸回転方向 Shaft rotational direction</th> <th style="width:30%;">信号 Signal</th> <th style="width:40%;">出力波形 Output</th> </tr> <tr> <td rowspan="2" style="text-align: center; vertical-align: middle;">時計方向 C. W.</td> <td>A(A-C端子間) A(Terminal A-C)</td> <td>ON --- OFF --- </td> </tr> <tr> <td>B(B-C端子間) B(Terminal B-C)</td> <td>ON --- OFF --- </td> </tr> <tr> <td rowspan="2" style="text-align: center; vertical-align: middle;">反時計方向 C. C. W.</td> <td>A(A-C端子間) A(Terminal A-C)</td> <td>ON --- OFF --- </td> </tr> <tr> <td>B(B-C端子間) B(Terminal B-C)</td> <td>ON --- OFF --- </td> </tr> </table>	軸回転方向 Shaft rotational direction	信号 Signal	出力波形 Output	時計方向 C. W.	A(A-C端子間) A(Terminal A-C)	ON --- OFF ---	B(B-C端子間) B(Terminal B-C)	ON --- OFF ---	反時計方向 C. C. W.	A(A-C端子間) A(Terminal A-C)	ON --- OFF ---	B(B-C端子間) B(Terminal B-C)	ON --- OFF ---	A. B2信号の位相差出力とし、詳細は<fig. 1>の通りとする。 (破線はクリック付きの場合のクリックの位置を示す。) 2 Phase-different signals (SignalA, signalB) Details shown in <fig. 1>. (The broken line shows detent position of with-detent type.)
		軸回転方向 Shaft rotational direction	信号 Signal	出力波形 Output											
		時計方向 C. W.	A(A-C端子間) A(Terminal A-C)	ON --- OFF ---											
			B(B-C端子間) B(Terminal B-C)	ON --- OFF ---											
反時計方向 C. C. W.	A(A-C端子間) A(Terminal A-C)	ON --- OFF ---													
	B(B-C端子間) B(Terminal B-C)	ON --- OFF ---													

ALPS ELECTRIC CO., LTD.				
	APPD 設2 93.B.-6 石川	CHKD W設2 '92.B.-3 溝淵	DSGD 設2 93.B.-3 三浦	TITLE ROTATIONAL ENCODER 回転形エンコーダ DOCUMENT NO. 4LA211-11 (1/5)
△ 2	74.03.03	石川	溝淵	三浦
SYMB	DATE	APPD	CHKD	DSGD

項目 Item	条件 Conditions	規格 Specifications
4-2 分解能 Resolution	1回転で出力されるパルス数 Number of pulses in 360° rotation.	各相 15パルス/360° 15 pulses/360° for each phase (2クリック1パルス) (2click 1pulse)
4-3 スイッチング特性 Switching characteristics	<p>下記回路<fig. 2>を用い、回転角を360°・S⁻¹の速さで回転し測定する。 Measurement shall be made under the condition as follows.</p> <p>1) Shaft rotational speed : 360°・S⁻¹ 2) Test circuit : <fig. 2></p> <div style="text-align: center;"> </div> <p><fig. 3></p> <div style="text-align: center;"> </div> <p>(注記) コードON状態 : 出力電圧が3.5V以上の状態を言う。 コードOFF状態 : 出力電圧が1.5V以下の状態を言う。 (note) Code-ON area : The area which the voltage is 3.5V or more. code-OFF area : The area which the voltage is 1.5V or less.</p>	
1) チャタリング Chattering	コードのOFF→ON及びON→OFFの際の、出力1.5V~3.5Vの通過時間にて規定する。 Specified by the signal's passage time from 3.5V to 1.5V or from 1.5V to 3.5V of each switching position (code OFF→ON or ON→OFF).	$t_1, t_3 \leq 2\text{ms}$
2) 揺動ノイズ (バウンス) Sliding noise (Bounce)	コードONの部分の3.5V以下の電圧変動時間とし、チャタリング t_1, t_3 両者との間に1ms以上の3.5V以上のON部分を有するものとする。また、揺動ノイズ間に3.5V以上の電圧が1msある場合は、別の揺動ノイズと判断する。 Specified by the time of voltage change exceed 3.5V in code-ON area. When the bounce has code-ON time less than 1ms between chatterings (t_1 or t_3), the voltage change shall be regarded as a part of chattering. When the code-ON time between 2 bounces is less than 1ms, they are regarded as 1 linked bounce.	$t_2 \leq 2\text{ms}$
3) 揺動ノイズ Sliding noise	コードOFFの部分の電圧変動 The voltage change in code-OFF area.	1.5V以下 1.5V MAX

ALPS ELECTRIC CO., LTD.					
					TITLE ROTATIONAL ENCODER 回転形エンコーダ
		APPD. 設2 93.8.-6 石川	CHKD. 設2 93.7.28 溝淵	DSGD. 設2 93.7.23 三浦	DOCUMENT NO. 4LA211-11 (2/5)
SYMB	DATE	APPD	CHKD	DSGD	OR

CLASS NO.	TITLE 回転形エンコーダ 規格書 ROTATIONALENCODER SPECIFICATION		(SW01)
項目 Item	条 件 Conditions		規 格 Specifications
4-4 位相差 Phase-difference	<p>360°・5⁻¹の定速にて操作軸を回転する。 Measurement shall be made under the condition which the shaft is rotated in 360°・5⁻¹ (constant speed).</p> <p><fig. 4></p> <p>注意事項 振動発点ですので手動操作時の出力波形はご使用されるツマミ毎、軸の回転速度によって変化致します。回路設計時は実機にて確認願います。 Note : Above specification (4-4) is changeable. when operate by manual. Please check performance using actual circuit and knob.</p>		<fig. 4>において ΔT ≥ 6msec In<fig. 4>
4-5 絶縁抵抗 Insulation resistance	端子-軸受間にD. C. 250V1mA印加する。 Measurement shall be made under the condition which a voltage of 250V D. C. 1mA is applied between individual terminals and bushing.		端子-軸受間にて100MΩ以上 Between individual terminals and bushing: 100MΩ MIN.
4-6 耐電圧 Dielectric strength	端子-軸受間にA. C. 300V1分間又は、A. C. 360V2秒間印加する。(リーク電流1mA) A voltage of 300V A. C. shall be applied for 1min or a voltage of 360V A. C. shall be applied for 2sec between individual terminals and bushing. (Leak current:1mA)		焼傷・アーク・絶縁破壊がないこと。 Without damage to parts arcing or breakdown.

560VA.C.

5. 機械的性能 Mechanical characteristics

項目 Item	条 件 Conditions		規 格 Specifications	
5-1 全回転角度 Total rotational angle			360° (エンドレス) 360° (Endless)	
5-2 クリックトルク Detent torque	→ (クリック付きのみ適用) (Applied for with-detent type)		12 ± 7mN・m (122.4 ± 71.4gf・cm)	
	回転トルク Rotational torque		(クリックなしのみ適用) (Applied for without-detent type)	5mN・m 以下。 (51gf・cm MAX.)
5-3 クリック点数及び位置 Number and position of detents.	→ (クリック付きのみ適用) (Applied for with-detent type)		30点クリック 30 detents (ステップ角度 12° ± 3°) (Step angle: 12° ± 3°)	
5-4 端子強度 Terminal strength	端子先端の任意の方向に5N(510gf)の静荷重を1分間加える。 A static load of 5N(510gf) be applied to the tip of terminals for 1minute in any direction.		端子の破損、著しいカタがないこと。 但し、端子の曲がりは可とする。 Without damage or excessive looseness of terminals. Terminal bend is permitted.	
5-5 軸の押し引き強度 Push-pull strength of shaft	軸の押し及び引き方向に100N(10.2kgf)の静荷重を10秒間加える。(セット実装状態) Push and pull static load of 100N(10.2kgf) shall be applied to the shaft in the axial direction for 10S. (After installing)		軸の破損、著しいカタがないこと。 感度異常がないこと。△ Without damage or excessive play in shaft. No excessive abnormality in rotational feeling.	

ALPS ALPS ELECTRIC CO., LTD.				
SYMB	DATE	APPD	CHKD	DSGD
△2	94-03-03	石川	溝淵	三浦
		APPD 投2 93.8.6 石川	CHKD WR2 92.7.28 溝淵	DSGD 投2 93.7.23 三浦
TITLE				ROTATIONALENCODER 回転形エンコーダ
DOCUMENT NO.				4LA211-11 (3/5)

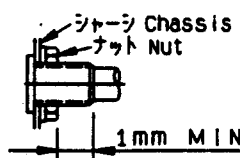
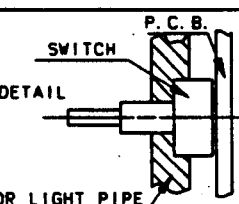
項目 Item	条件 Conditions	規格 Specifications
5-6 軸受ネジ締付強度 Bushing nut tightening strength	(ネジ 付きのみ適用) (Applied for with-thread type) <fig. 5>を満足するように締付る。 Tighten the nut according to <fig. 5> <div style="text-align: right;">  <p>シャフト Chassis ナット Nut 1mm MIN</p> </div>	1N·m(10.2kgf·cm)以上 1N·m(10.2kgf·cm) MIN.
5-7 軸力ワobble Shaft wobble	軸先端から5mmの位置に50mN·m(510gf·cm)の曲げモーメントを加える。 A momentary load of 50mN·m(510gf·cm) shall be applied at the point 5mm from the tip of the shaft in a direction perpendicular to the axis of shaft.	軸受長 Bushing length (mm) 軸力ワobble wobble (mm)以下 (mm-p less) 3.5 1.4xL/30 5 1.1xL/30 7 0.7xL/30 Lは取付長さで比例計算する。 L: Measurement point from mounting surface of bushing.
5-8 軸のスラスト方向力ワobble Shaft play in axial direction		0.4mm-p以下 0.4mm-p MAX.
5-9 軸の回転方向力ワobble Rotation play at the click position	(クリック付きのみ適用) (Applied for with-detent type) 角度板にて測定する。 Measure with jig for rotational angle.	5度以内 5° MAX.
5-10 はんだ耐熱 Resistance to soldering heat	7項の「はんだ付け条件」による。 Specified by the clause 7 "Soldering conditions".	絶縁体の変形、破壊のないこと。 絶縁に異常のないこと。 There shall be no deformation or cracks in molded part. No excessive abnormality in rotational feeling.
5-11 取付け上の注意 Notice for mounting	右図の様にスイッチ本体を挿えてご使用下さい。セット側でスイッチ本体の引き及び回転方向の力「イト」が無い場合は、はんだ付けだけの固定となり、はんだ付け信頼性及びスイッチ本体強度が不安定となる可能性があります。 Hold the bushing use front panel or light pipe. Because this switch not has thread. If don't hold the bushing, the switch maybe become intermittent or rough mounting after soldering by knob stopper face.	

6. 耐久性能 Endurance characteristics.

項目 Item	条件 Conditions	規格 Specifications
6-1 しゅう動寿命性能 Rotational life	無負荷で軸を毎時500サイクルの速さで、15,000回転断続動作を行う。 但し、試験途中5,000で中間測定を行う。(1サイクルは、360°1往復) The shaft of encoder shall be rotated to 15,000 cycles at a speed of 500cycles per hour without electrical load. after which measurements shall be made. However, an interim measurement shall be made immediately after 5,000 cycles. (1 cycle: rotate 360° CCW rotate 360° CW)	クリックトルク: 初期規格値に対し ^{+10%} その他、初期規格を満足すること。 Detent torque: Relative to the previously specified value. $\pm 10\%$ Except above items, specifications in clause 4.1-6 Δ and 5.1-3 shall be satisfied.

 ALPS ELECTRIC CO., LTD.					
SYMB	DATE	APPD	CHKD	DSGD	TITLE ROTATIONAL ENCODER 回転形エンコーダ
2	94.03.03	石川	三浦	三浦	DOCUMENT NO.
		設2 93.8.-6 石川	設2 92.7.28 溝淵	設2 93.7.23 三浦	4LA211-11 (4/5)

CLASS No.	TITLE
-----------	-------

7. はんだ付け条件 Soldering conditions

7-1 手はんだの場合 Manual soldering

温度300°C以下、時間3秒以内
 Bit temperature of soldering iron : 300°C or less.
 Application time of soldering iron : within 3s.

7-2 チップはんだの場合 Dip soldering

使用基板 : t1.6両面銅箔基板
 Printed wiring board: Both-sided copper clad laminate board with thickness of 1.6mm.

フラックス : 比重0.82以上のフラックスを用い泡発式フラクサーにて発泡高さは、基板厚の3分の2。

Flux:
 ・Specific gravity: 0.82 or more.
 ・Flux shall be applied to the board using a bubble foaming type fluxer.
 ・The board shall be soaked in the flux bubble only to the 2/3 of its thickness.

プリヒート : 基板表面温度100°C以下、時間1分以内
 Preheating:
 ・Surface temperature of board: 100°C or less.
 ・Preheating time: within 1 min.

はんだ : 温度260°C以下、時間3秒以内
 Soldering:
 ・Solder temperature: 260°C or less.
 ・Immersion time: Within 3s.

以上の工程を1回または2回繰り返す。
 Apply the above soldering process for 1 or 2 times.

					 ALPS ELECTRIC CO., LTD.		
				APPD.	CHKD.	DSGD.	TITLE ROTATIONAL ENCODER
				投2 93.6.-6	投2 92.7.28	投2 93.7.23	回転エンコーダ
				石川	溝淵	三浦	DOCUMENT NO.
SYMB	DATE	APPD	CHKD	DSGD			4LA211-11 (5/5)

OR

注記 軸受材質：亜鉛合金ダイカスト
 銅材質：アルミニウム

NOTES BUSHING MATERIAL: ZINC ALLOY DIE CASTING
 SHAFT MATERIAL: ALUMINIUM

スリ割り角度は任意とする。
 SHAFT SLOT IS
 OPTIONAL ANGLE

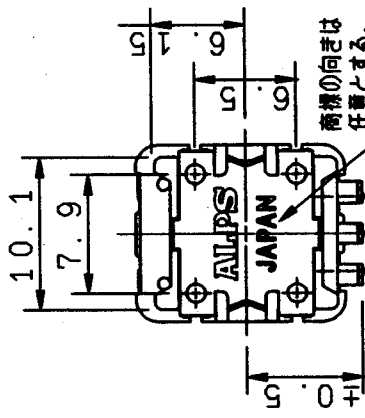
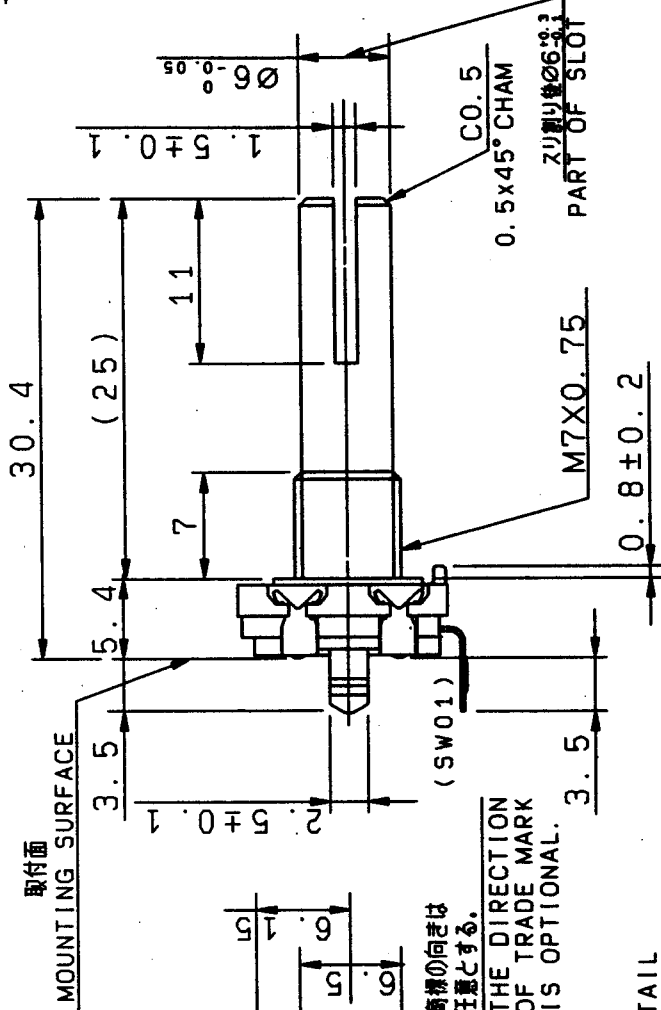
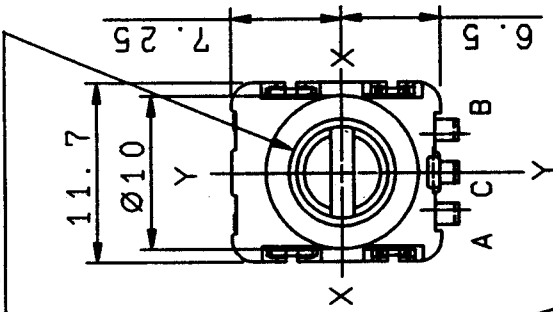

商標の向きは任意とする。
 THE DIRECTION OF TRADE MARK IS OPTIONAL.

取付寸法図 許容差±0.1
 (挿入側より)

P.W.B. MOUNTING DETAIL
 TOLERANCE±0.1
 VIEWED FROM MOUNTING SIDE

11.1 ± 0.05

基板厚 t=1.6mm
 P.C.B.

シヤージ止の詳細図
 LOCATING LUG DETAIL

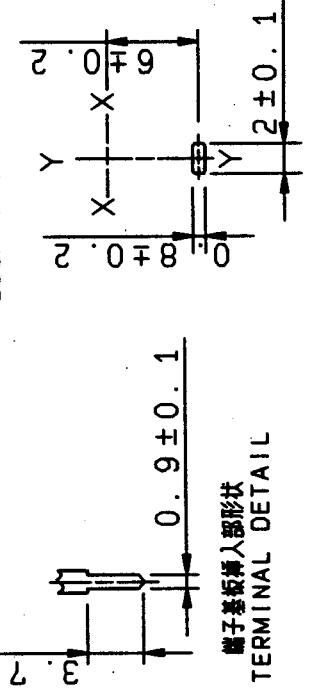

端子基板挿入部形状
 TERMINAL DETAIL

指定なき部分の許容差 TOLERANCES UNLESS OTHERWISE SPEC	L ≤ 10	±0.3
	10 < L < 100	±0.5
	100 ≤ L	±0.8
角度 ANGULAR DIMENSION		±5°

PART NO.	NAME	MATERIAL NAME & CODE	FINISH
----------	------	----------------------	--------

ALPS ELECTRIC CO., LTD.

SYMB	DATE	APPD	CHKD	DSGD	UNIT. mm	SCALE	TITLE 11形1軸 薄形エンコータ -
		1-設2 94.11.16 溝淵	1-設2 94.11.16 竹沢	1-設2 94.11.15 三浦			DOCUMENT NO. LA2110423

OR